

# Audio Interface Harness Adapter

## Installation Guide (for BOSE equipped 2015-20 QX60, 14-Speaker System)

1. Ensure the car is OFF and locate the BOSE Amp under the 3<sup>rd</sup> row seat or factory subwoofer in the trunk (see diagram below), depending on the type of kit you ordered.
  2. Use a medium sized flathead screwdriver to press in the latching clip & **carefully disconnect** the connectors from the Bose Amp or Subwoofer that will attach to the harness adapter.
  3. Plug the adapter into the corresponding connectors as appropriate. Also make any connections between the adapter itself, if applicable.
  4. Refer to the harness adapter's labeling and the diagram below to connect your audio equipment.
    - Hi-Level Output wiring is labeled "OUT", with a speaker number for reference. For example, "OUT 2" is the hi-level output to the Front Left Dashboard Tweeter. Hi-level output wiring goes to the Input of your Amp/DSP/LOC. *Keep in mind the hi-level outputs from the factory amp are usually filtered (i.e. not full range audio signals). Therefore, you may want to feed the outputs to summing equipment before your amplifier(s) to get full range signals for your amp(s), if desired. The diagram below can be used to help determine the audio range of each output.*
    - Speaker Wiring (if your adapter has it) is labeled with a speaker number, in reference to the diagram below. Speaker wiring goes to the Output of your amplifier(s).
- Note: Gray or Red wire connections are + (Positive). Black wire connections are - (Negative).

### 2015-16 QX60 OUTPUT / SPEAKER WIRING DIAGRAM

- 1 - Center Speaker**  
(mid and high range)
- 2 - Front Left Dashboard Tweeter**  
(high range)
- 3 - Front Right Dashboard Tweeter**  
(high range)
- 4 - Front Left Tweeter and Speaker**  
(high, mid, and low range)
- 5 - Front Right Tweeter and Speaker**  
(high, mid, and low range)
- 6 - Rear Left Tweeter and Speaker**  
(high, mid, and low range)
- 7 - Rear Right Tweeter and Speaker**  
(high, mid, and low range)
- 8 - Rear Left Pillar Speaker**  
(high, mid, and low range)
- 9 - Rear Right Pillar Speaker**  
(high, mid, and low range)
- 10 - Subwoofer**  
(low range)

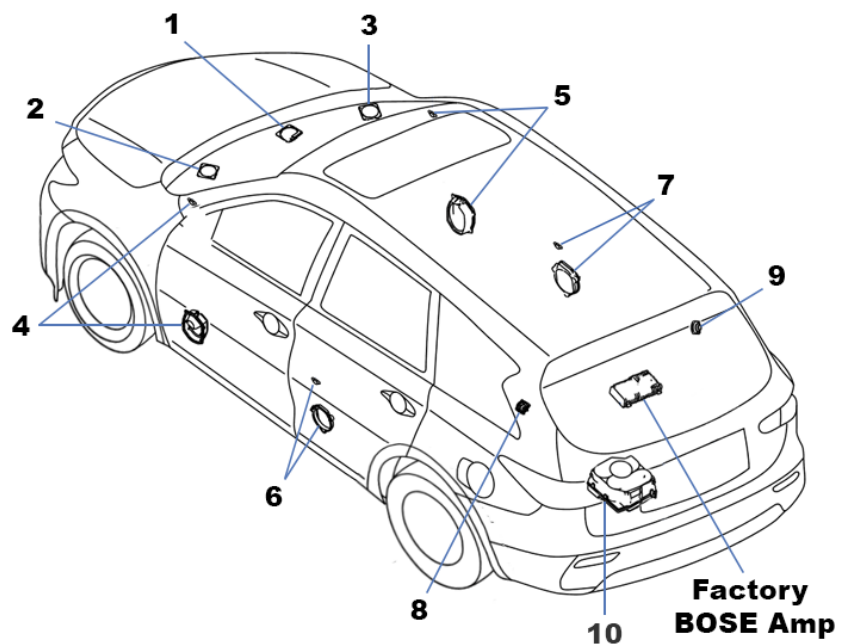

## 2017-20 QX60 OUTPUT / SPEAKER WIRING DIAGRAM

- 1 - Center Speaker**  
(mid range)
- 2 - Front Left Dashboard Tweeter**  
(high range)
- 3 - Front Right Dashboard Tweeter**  
(high range)
- 4 - Front Left Tweeter and Speaker**  
(high range and low range)
- 5 - Front Right Tweeter and Speaker**  
(high range and low range)
- 6 - Rear Left Tweeter and Speaker**  
(high range and mid range)
- 7 - Rear Right Tweeter and Speaker**  
(high range and mid range)
- 8 - Rear Left Pillar Speaker**  
(mid range)
- 9 - Rear Right Pillar Speaker**  
(mid range)
- 10 - Subwoofer**  
(low range)

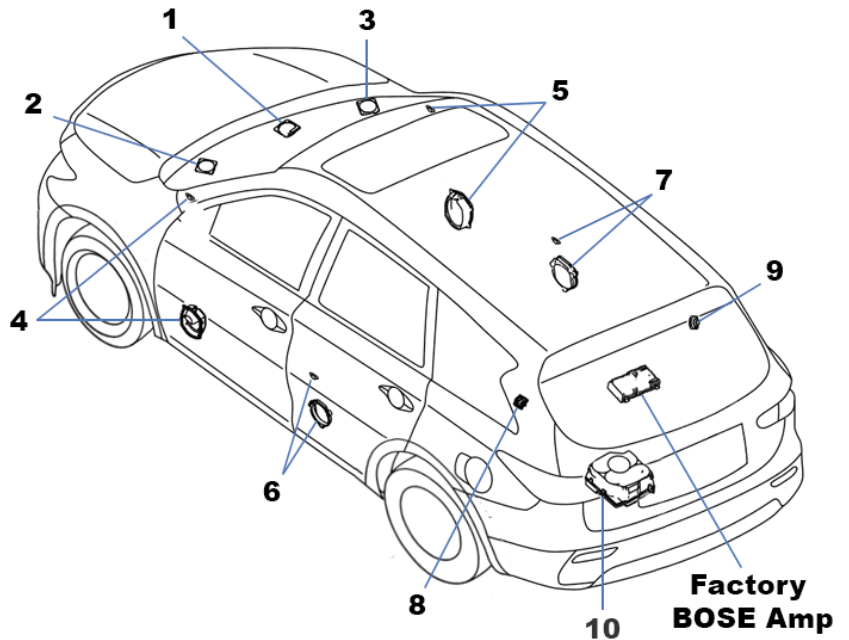

5. After making the connections you want to your audio equipment, be sure to **properly secure** any remaining/unused connections of the adapter to avoid any shorts or damage.
6. Once all your connections have been made and everything is secure, you can turn the car on to test everything out. Ensure everything looks and sounds ok.
7. Adjust your equipment settings as necessary, and that's all there is to it!

**Enjoy Your New Upgrade!**