

Audio Interface Harness Adapter

Installation Guide (for NON-Bose 2014-23 Q50)

1. Ensure the car is OFF and disconnect the car battery cable from the negative terminal.
2. Remove the radio/av unit and connect the main adapter to the 20-pin radio & harness connection.
3. Run the extension cable(s) to a location of your choice to connect your amplifier(s) and connect the cable to the main section of the harness adapter.
4. If your kit has an ANC Bypass, locate the ANC Unit on the rear trunk shelf and connect the adapter to the corresponding connectors as appropriate. Note that the adapter also has a bypass connection for ASE (Active Sound Enhancement, a.k.a. Fake Exhaust Sound).
5. Refer to the labeling on the adapter to connect your audio equipment.

The radio outputs high-level (aka speaker level) audio signals that go through the wiring of the harness adapter. Therefore, we recommend audio equipment that has high-level inputs, differential inputs, or inputs capable of accepting preamp and speaker-level signals. Otherwise, you may need to use an appropriate Line Output Converter to connect your equipment.

 - Speaker Wiring (if your adapter has it) is labeled with a speaker number, in reference to the diagrams below. Speaker wiring goes to the Output of your amplifier(s).

Note: Gray or Red wire connections are + (Positive). Black wire connections are - (Negative).

2014-16 Q50 SPEAKER WIRING DIAGRAM

- 1 - Front Right Mid and Speaker**
- 2 - Front Left Mid and Speaker**
- 3 - Rear Right Speaker**
- 4 - Rear Left Speaker**

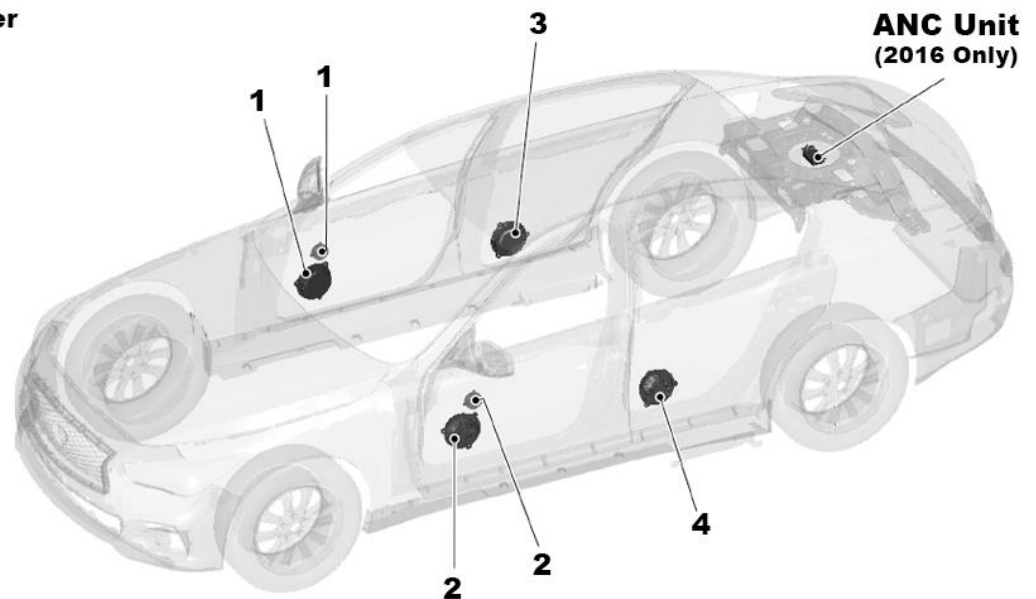

2017-23 Q50 SPEAKER WIRING DIAGRAM

- 1 - Front Right Tweeter and Speaker**
- 2 - Front Left Tweeter and Speaker**
- 3 - Rear Right Speaker**
- 4 - Rear Left Speaker**

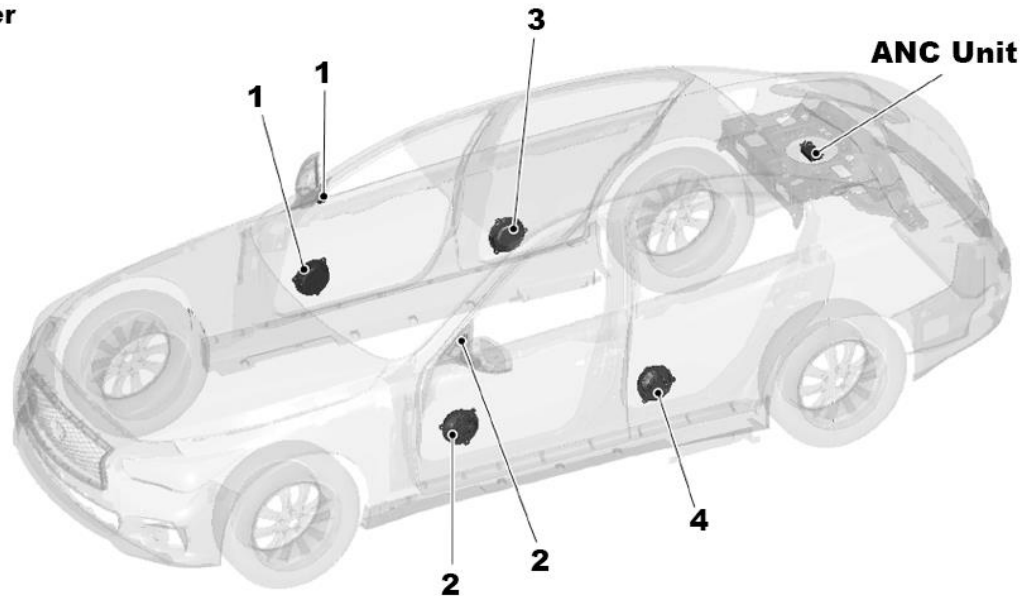

6. After making the connections you want to your audio equipment, be sure to **properly secure** any remaining/unused connections of the adapter to avoid any shorts or damage.
7. Once all your connections have been made and everything is secure, you can reconnect the negative battery terminal and turn the car on to test everything out. Ensure everything looks and sounds ok.
8. Re-install any removed car parts and then reconnect the negative battery terminal, if necessary.
9. Reset the car windows auto-up function (necessary when battery disconnected): Press and hold the window down button until the window is fully open. Release. Pull and hold the window up function for 6 seconds. Windows should now go up/down properly with the auto function. Repeat for all windows as necessary (can do two at once).
10. Adjust your equipment settings as necessary, and that's all there is to it!

Enjoy Your New Upgrade!