

Audio Interface Harness Adapter Installation Guide

(for BOSE equipped NON-Nismo 2015-16 GT-R and any BOSE equipped 2017-18 GT-R)

1. Ensure the car is OFF and locate the BOSE Amp under the driver's seat if you purchased a harness adapter that plugs into the Bose Amp Harness. *For seats with side air bag, disconnect the car battery cable from the negative terminal and wait for at least 3 minutes. Then disconnect the seat's harness connector before removing the seat.*

If you purchased an adapter that plugs into the factory subwoofer harness, locate the connectors at the subwoofer housing after removing the rears seats and center pieces.

2. Use a medium sized flathead screwdriver to press in the latching clip & **carefully disconnect** the connectors from the Bose Amp and/or Subwoofer that will attach to the harness adapter.
3. Plug the adapter into the corresponding connectors as appropriate. Also make any connections between the adapter itself, if applicable.

4. Refer to the harness adapter's labeling and the diagram below to connect your audio equipment.

- Hi-Level Output wiring is labeled "OUT", with a speaker number for reference. For example, "OUT 4" is the hi-level output to the Front Left Door Speaker.

Hi-level output wiring goes to the Input of your Amp/DSP/LOC.

Keep in mind the hi-level outputs from the factory amp are usually filtered (i.e. not full range audio signals). Therefore, you may want to feed the outputs to summing equipment before your amplifier(s) to get full range signals for your amp(s), if desired. The diagrams below can be used to help determine the audio range of each output.

- Speaker Wiring (if your adapter has it) is labeled with a speaker number only. Speaker wiring goes to the Output of your amplifier(s).

Note: Gray or Red wire connections are + (Positive). Black wire connections are - (Negative).

OUTPUT / SPEAKER WIRING DIAGRAM

- 1 - Center Speaker**
(mid range)
- 2 - Front Left Tweeter and Mid**
(high range and mid range)
- 3 - Front Right Tweeter and Mid**
(high range and mid range)
- 4 - Front Left Door Speaker**
(high and mid range)
- 5 - Front Right Door Speaker**
(high and mid range)
- 6 - Rear Left Speaker**
(high and mid range)
- 7 - Rear Right Speaker**
(high and mid range)

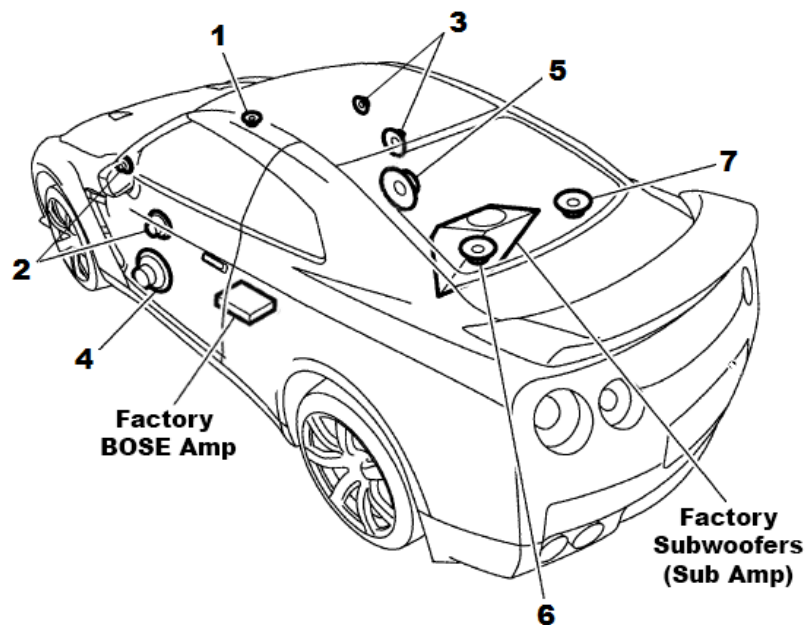



- Subwoofer Harness Adapters have an RCA Cable that goes to the Input of your Sub Amp.
The Bose system outputs low-level differential balanced signals (that go through the specifically designed RCA connections of the adapter). Therefore, we recommend audio equipment that has differential inputs, or RCA inputs capable of accepting preamp and speaker-level signals. Otherwise, you may need to use an appropriate Line Output Converter to avoid sound quality issues.
- 5. After making the connections you want to your audio equipment, be sure to **properly secure** any remaining/unused connections of the adapter to avoid any shorts or damage.
- 6. Once all your connections have been made and everything is secure, you can turn the car on to test everything out. Ensure everything looks and sounds ok.
Note: You may want to disconnect the ANC (Active Noise Control) connection on the harness adapter (if built into your kit) or turn ANC off in the System Diagnostic Menu of the factory radio, to prevent it from interfering with the sound quality of your new audio upgrade.
- 7. Re-install any removed car parts and then reconnect the negative battery terminal, if necessary.
- 8. Reset the car windows auto-up function (necessary when battery disconnected): Press and hold the window down button until the window is fully open. Release. Pull and hold the window up function for 6 seconds. Windows should now go up/down properly with the auto function.
Repeat for all windows as necessary (can do two at once).
- 9. Adjust your equipment settings as necessary, and that's all there is to it!

Enjoy Your New Upgrade!